

2 KAPILI DOLAP KURULUMU

Assembly and User Manual

Montaj ve Kullanım Klavuzu / Montage- und Bedienungsanleitung

Installation et Mode d'Emploi. / Инструкция по монтажу и эксплуатации

Product Code / Ürün Kodu / Artikelnr / Code du Produit. / Артикул изделия /

OGNC-202

Product Name / Ürün Adı / Artikelbezeichnung / Nom du Produit. / Название изделия /

2 KAPILI DOLAP / 2 DOORS CABINET

Product Size / Ürün Ebadı / Artikelma e / Dimensions du Produit. / Размер изделия /

80X47X195



This module must be assembled by two persons.

Bu modul 2 kişi tarafından kurulmalıdır.

Dieses Produkt sollte von 2 Personen montiert werden

Ce module doit être installé par 2 personnes.

Данный модель устанавливается 2 человеками.



The necessary tools required for assembly of this module

Bu modülün kurulumu için gerekli araçlar

Notwendige Werkzeuge für die Montage

Outils nécessaires pour l'installation de ce module.

Инструменты, необходимые для установки мо

2x

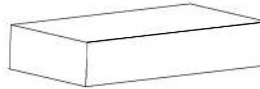

Sayın Müşterimiz, Satın almış olduğunuz ürün sizlerin güvenliği düşünülerek gerekli kontrol ve testlere tabi tutularak tarafınıza ulaştırılmıştır. Ürünlerin kurulum, bakım ve kullanımında dikkat edilmesi gereken hususlar kullanma talimatında yer almaktadır. Kurulumu başlamadan önce mutlaka kullanma kılavuzunu okuyunuz. Montaja başlamadan önce kutulardan çıkan tüm parça ve aksesuarları kontrol ediniz. Parça ve aksesuarların sağlam olduğunu tespit ettikten sonra montaja başlayınız. Ürün montajını önerilen sayıda kişi ile gerçekleştiriniz. Montaja başlamadan önce her parçayı kullanım kılavuzunda anlatıldığı şekilde nemli bir bez ile temizleyiniz. Birden fazla ürün alımlarında ürün kurulumunda herhangi bir karışıklığa sebebiyet vermeme için bir ürünün montajını tamamladıktan sonra diğer ürüne geçiniz. Ürünlerinizi hiçbir zaman sürükleyerek taşımayınız. Ürününüzü kaldırarak ve sökerek en az iki kişi taşıyınız. Uzun mesafeli taşımalarda ürün parçalarını ambalajlayarak taşıyınız. Kurulumu başlamadan önce zemine, ürün yüzeylerinin çizilmesini engelleyecek şekilde battaniye veya benzeri yumuşak bir malzeme seriniz.

Dear Customer, The product that you purchased is delivered to you after necessary controls and tests to guarantee your safety. The issues that must be cared during the assembly, maintenance and use is provided in the user instructions. Before assembly, please absolutely read the user manual. Before starting assembly, check all necessary parts and accessories are included and complete in the box. After verifying that parts and accessories are intact, initiate the assembly. Perform the assembly of the item with the number of persons recommended. Before starting the assembly, clean all the parts with a damp cloth as explained in the user manual. In multiple product purchases, please first complete one item's assembly then proceed with the other items, in sequence, to avoid any confusion. Never handle your products by dragging it. Handle your products as demounted and being lifted above the ground with at least two persons. For long distances, handle your products' parts in a package. Place a blanket or a similar soft material on the floor before commencing assembly to prevent scratching of product surfaces.

KULLANILAN AKSESUAR

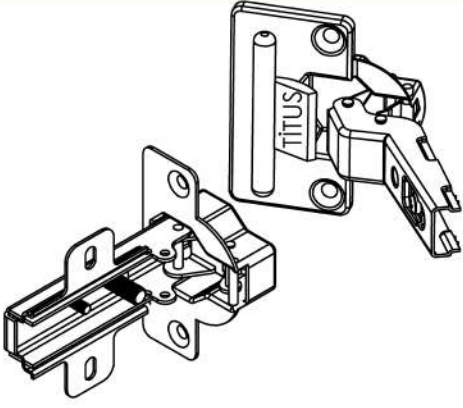

MENTEŞE
(6 ADET)

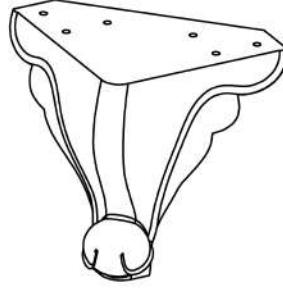

AYAK
(5 ADET)

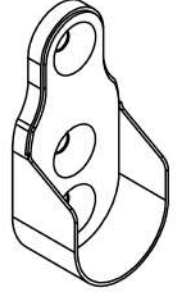

ASKI FLANŞI
(2 ADET)

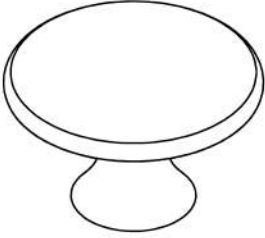

KULP
(3 ADET)



LED ASKI BORUSU
36,5 X 3.5
(1 ADET)



H PROFİL
170 X 1 CM
(1 ADET)



3.5 X 50
(8 ADET)



4 X 40
(3 ADET)
Taç Vidası



4 X 30
(30 ADET)
Ayak Vidası



3.5 X 25
(40 ADET)
Dolap ve Çekmece
Arkası montajı için



KAVELA
(8 ADET)

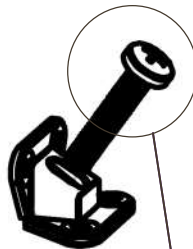

Bağlantı Vidası
(20 ADET)



3.5 X 18
(24 ADET)

1. AŞAMA

3.5 x 25 vida ile ayaklar alt tablaya vidalanır.

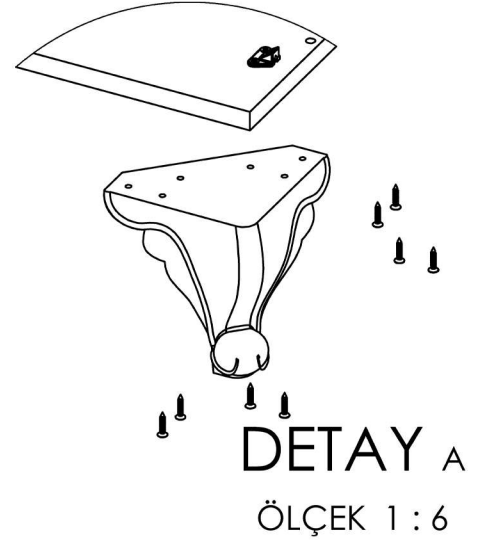
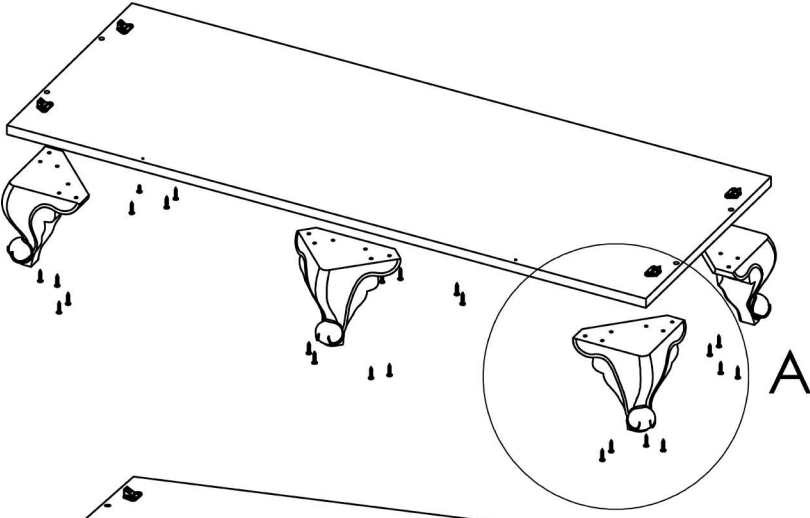

DETAY A

ÖLÇEK 1:6

Alt etek 4 x 30 vida ile alt tablaya vidalanır.

1 OSLO VE RIO KUTU AYAK KURULUMU

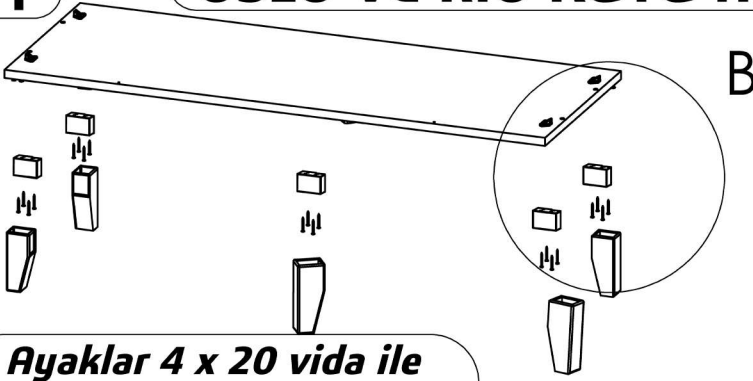

DETAY B

ÖLÇEK 1:7

Ayaklar 4 x 20 vida ile alt tablaya vidalanır.

2 Etekler ayaklara geçirilerek 4 x 70 vida ile montajı tamamlanır.

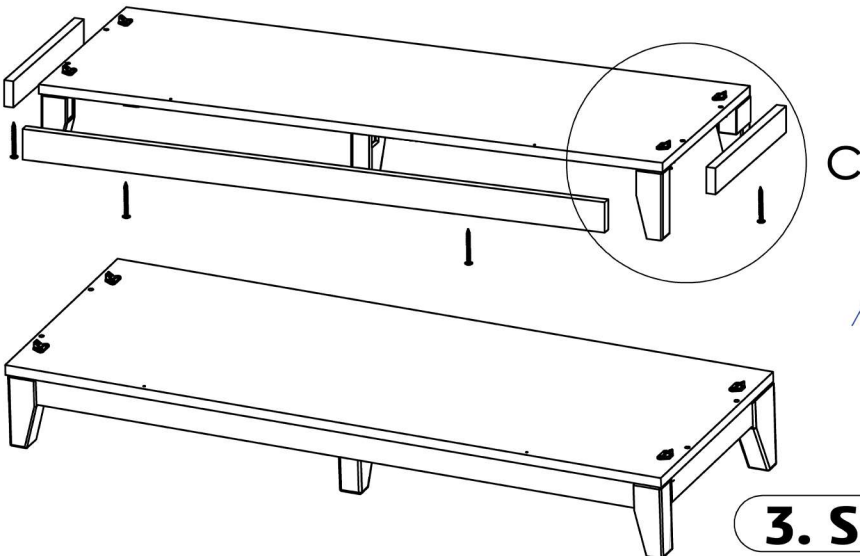

C

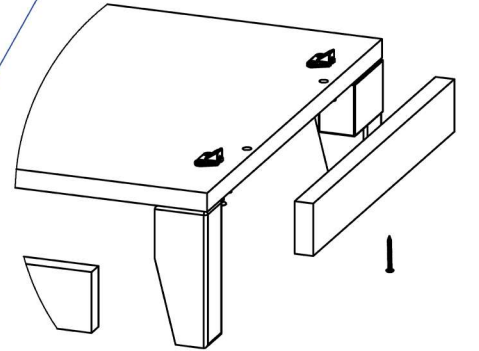

DETAY C

ÖLÇEK 2:13

3. SAYFA

2. AŞAMA

sağ yan dikmenin kavale deliklerine kavaleler geçirilir ve alt tablanın kavale deliklerine geçirilir.

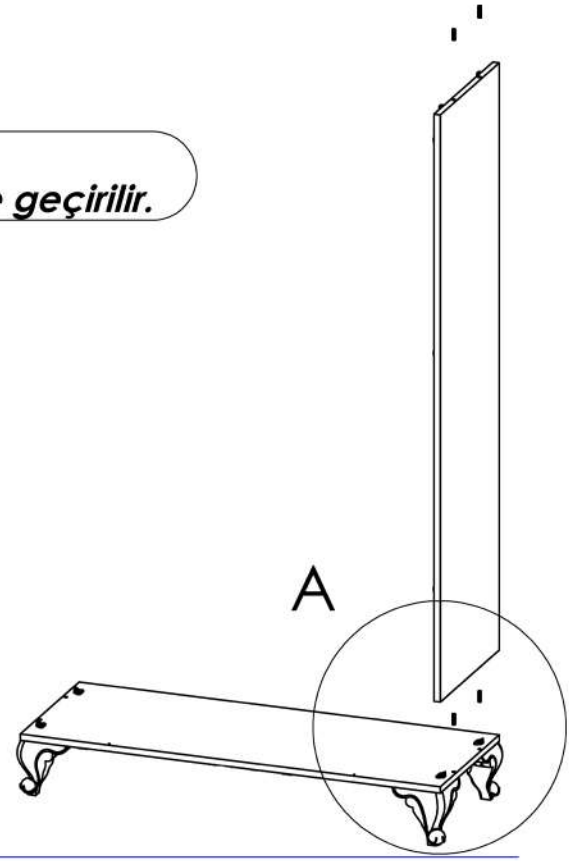
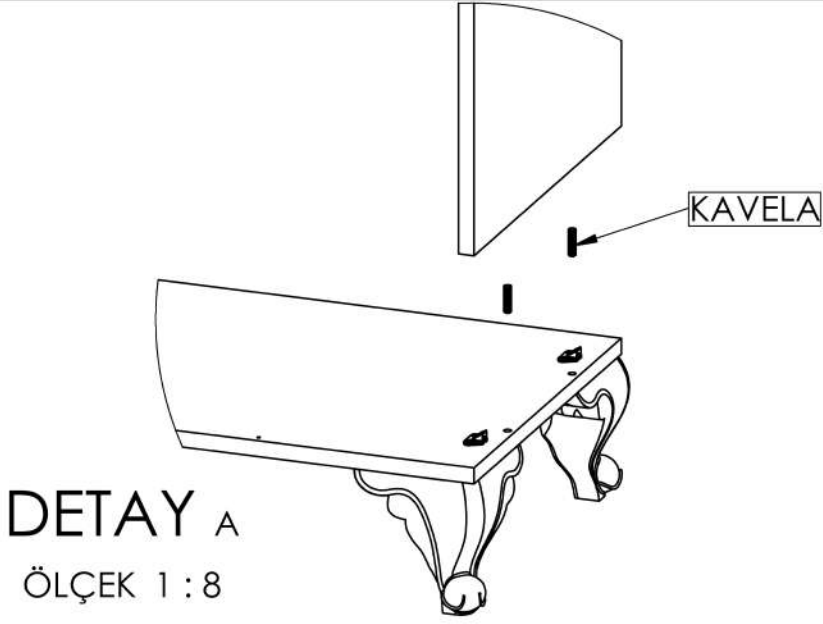

Alt tablaya geçirilen sağ yan dikme çektiirme vidası sıkılarak birbirine sabitlenir.

MANTAR BAŞLI VİDA

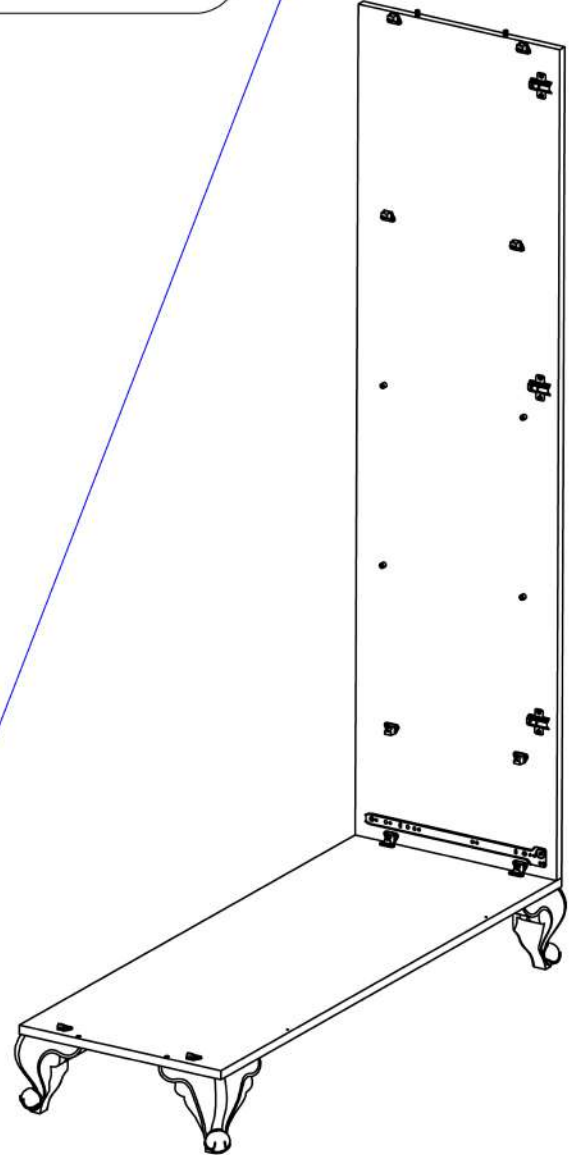
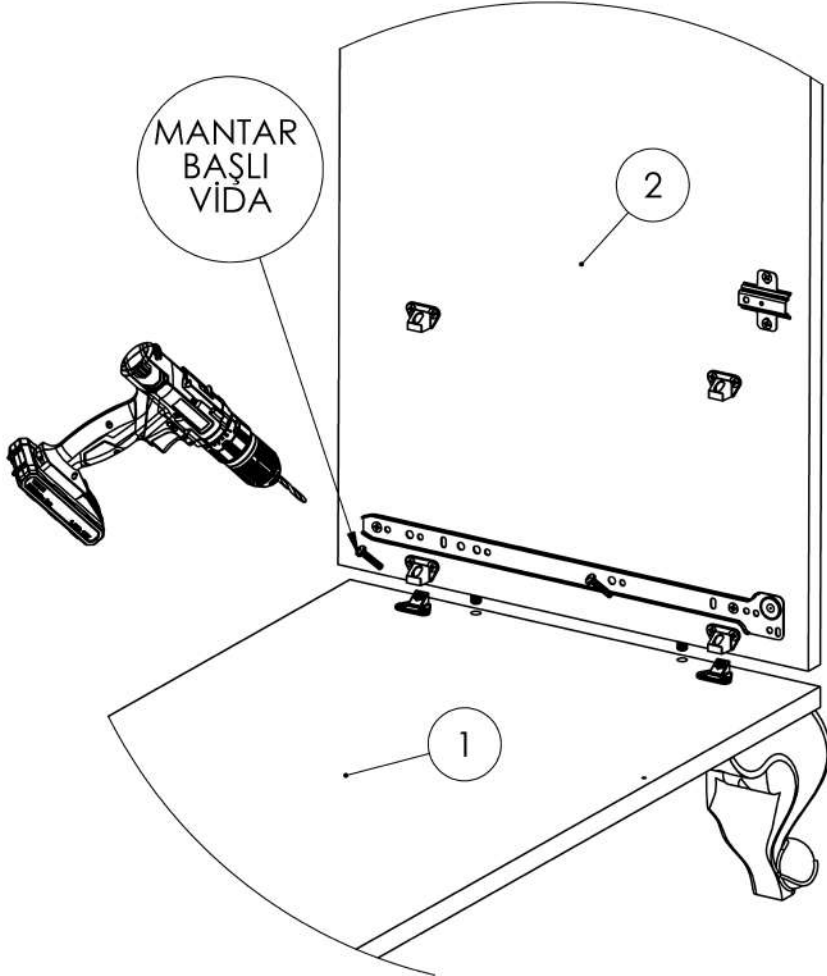

3. AŞAMA

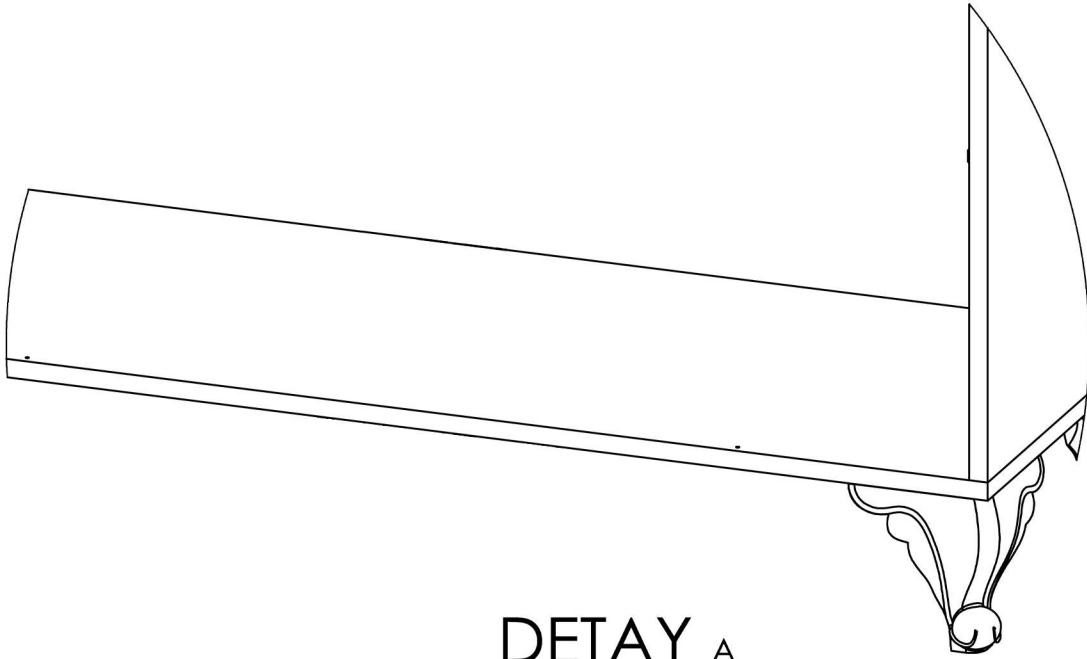
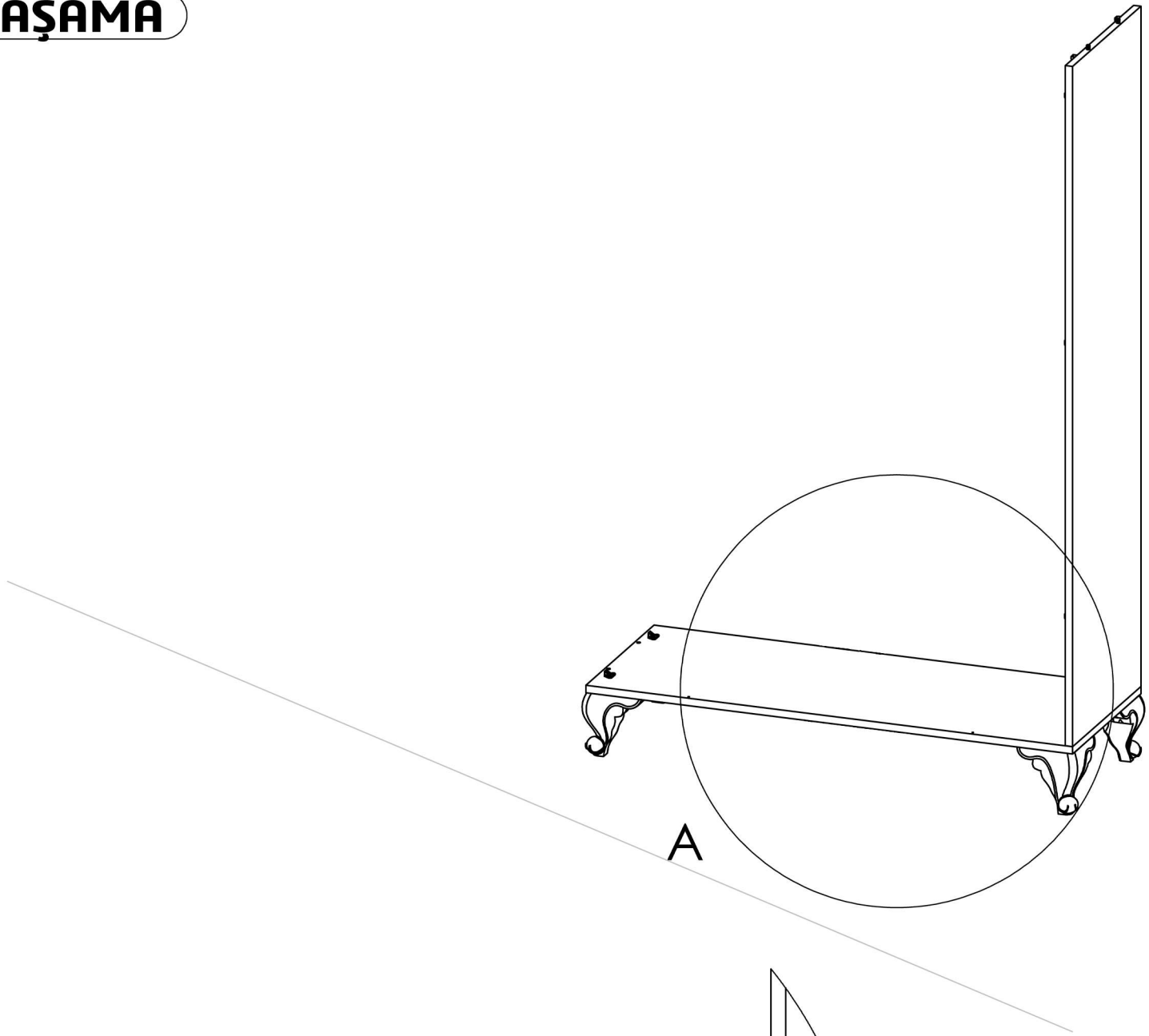

DETAY A

ÖLÇEK 1 : 7

4. AŞAMA

sol yan dikmenin kavale deliklerine kavaleler geçirilir ve alt tablanın kavale deliklerine geçirilir.

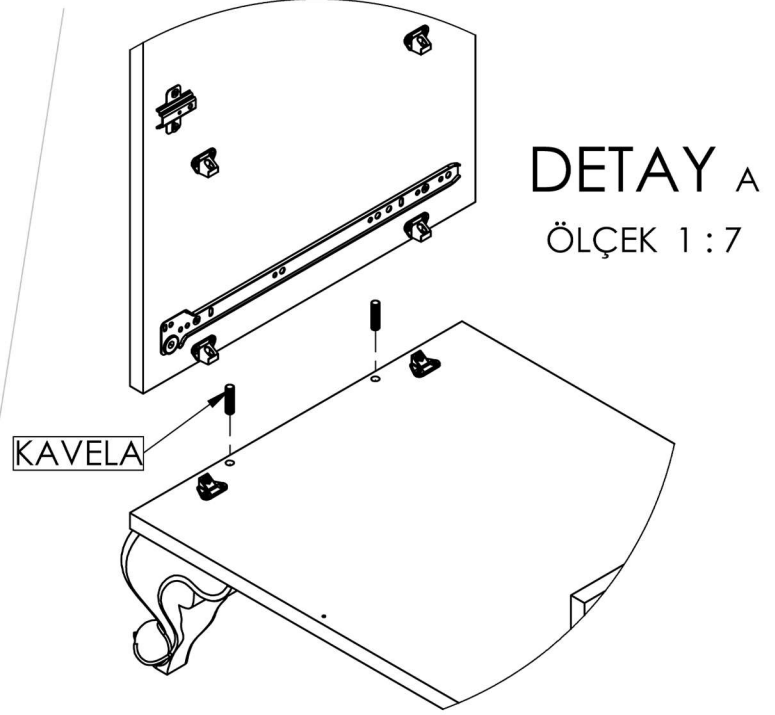
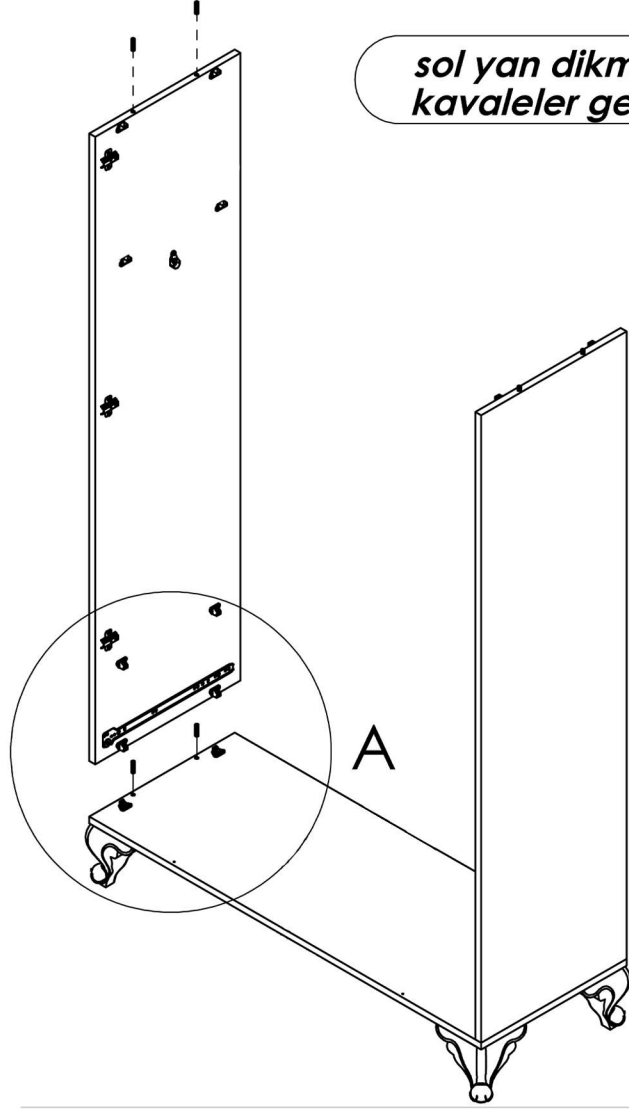

Mantar kafa vida ile sol yan dikme ve alt tabla birbirine bağlanır.

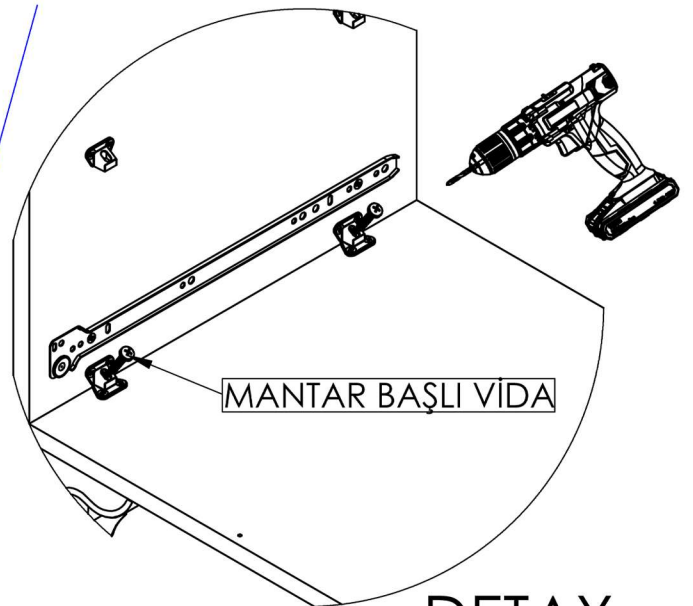
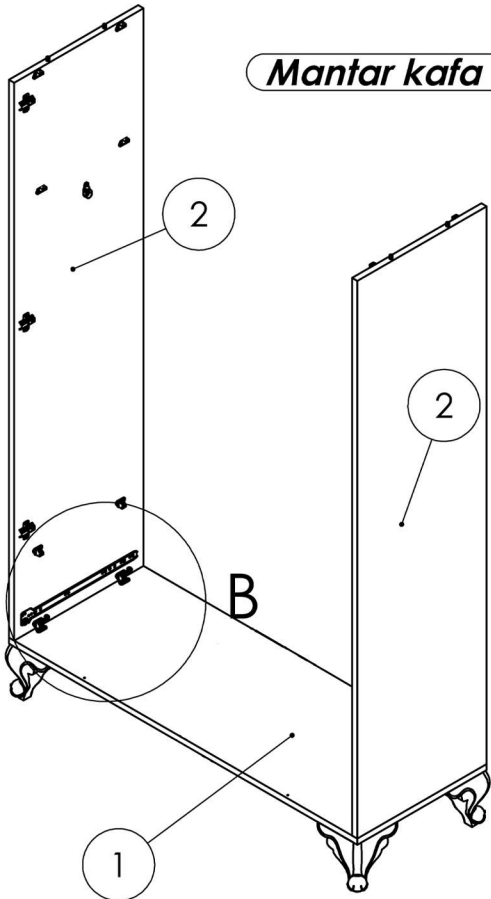

5. AŞAMA

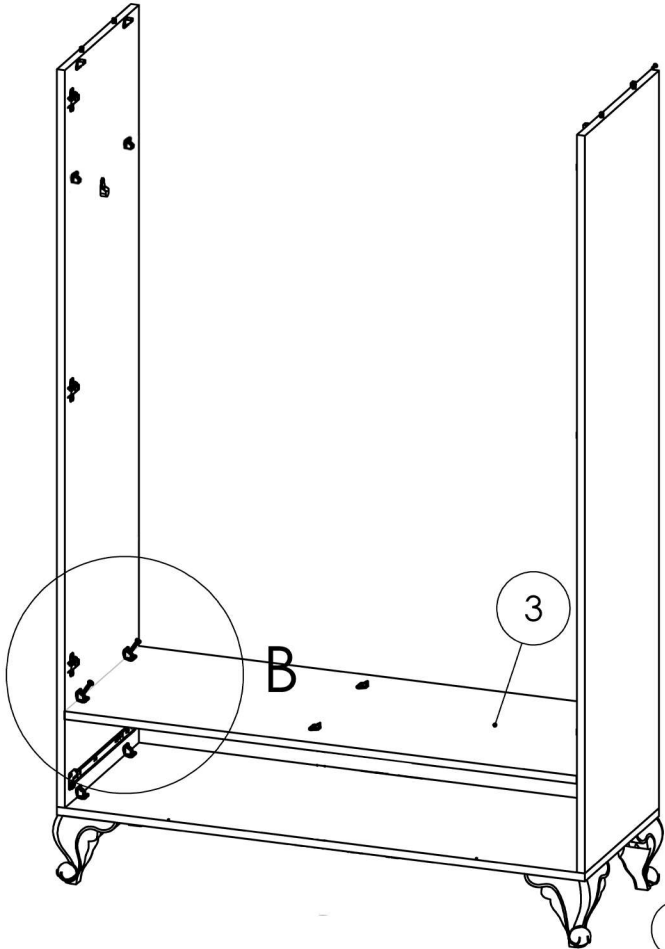
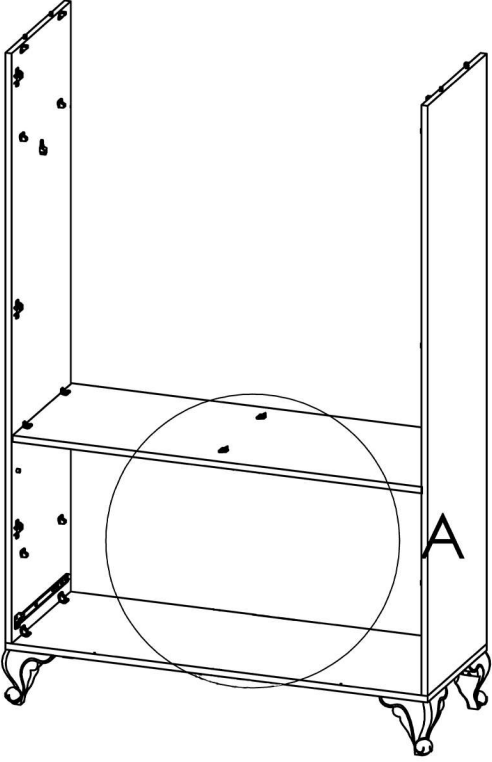

7. SAYFA

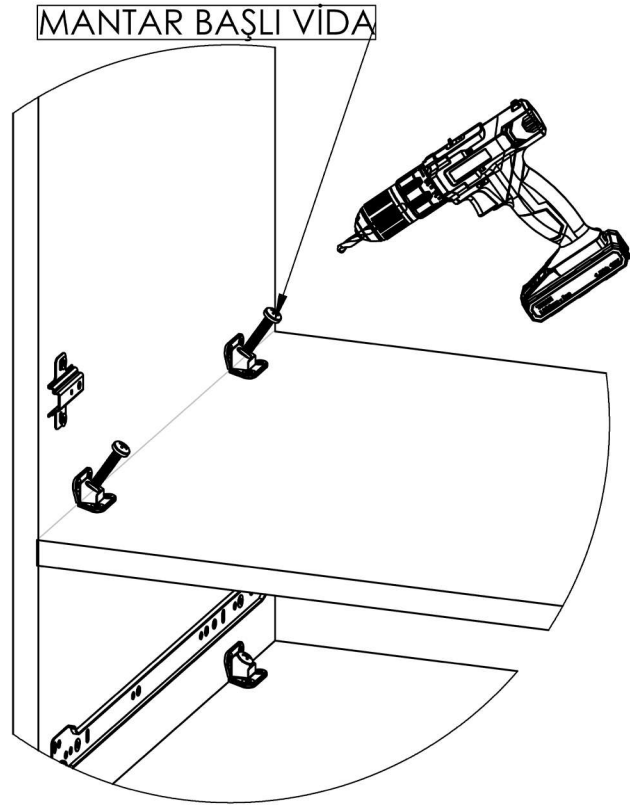

DETAY B

ÖLÇEK 1 : 5

6. AŞAMA

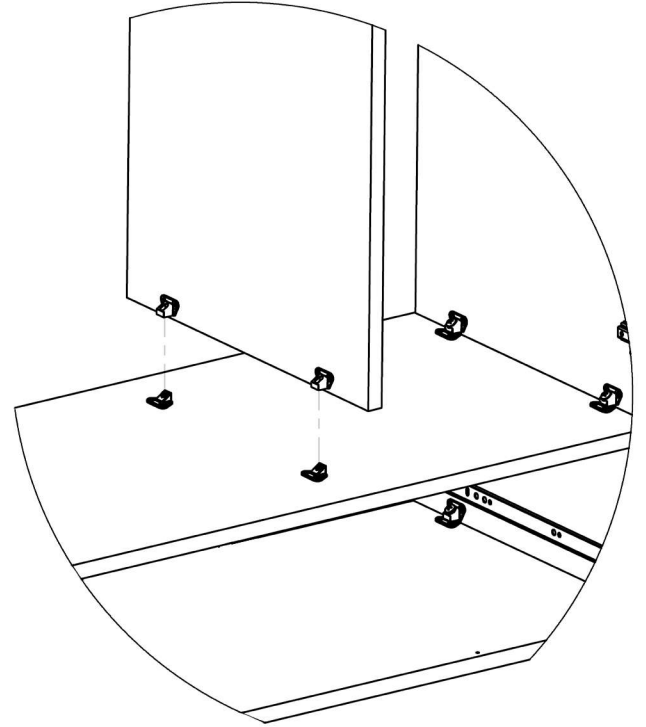
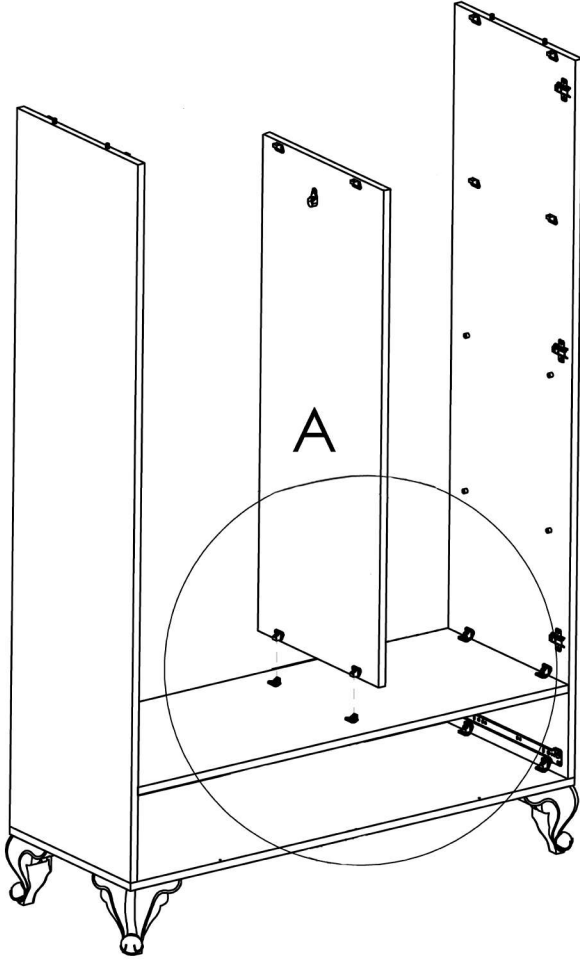

DETAY A

ÖLÇEK 1 : 8

Orta dikme çekirme vidası ile çekmece üstü ile birbirine birleştirilir.

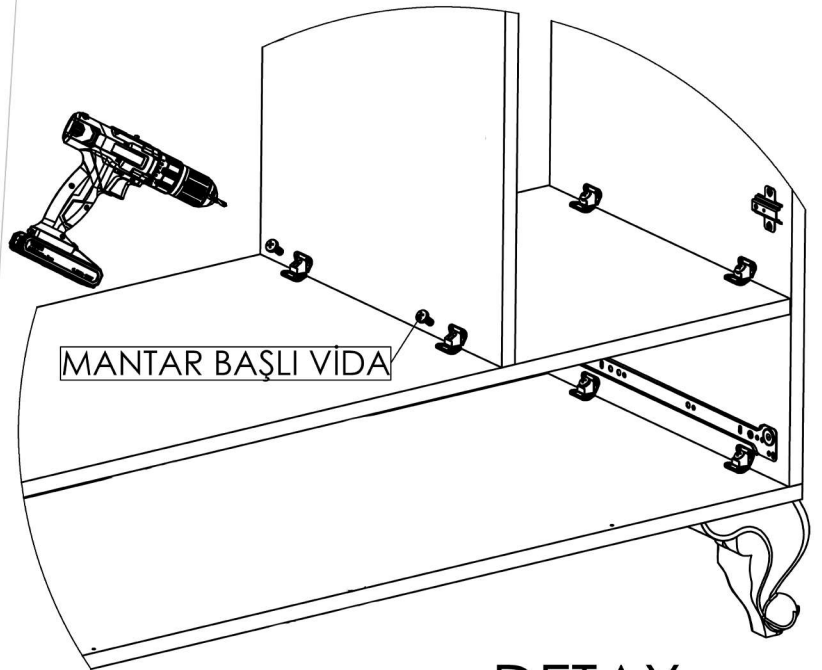
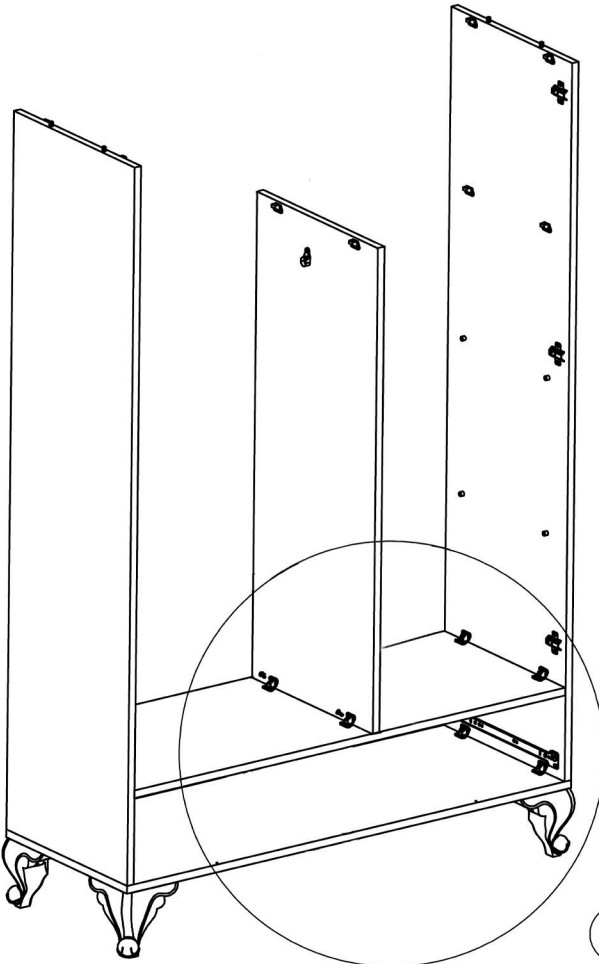

DETAY B

ÖLÇEK 1 : 8

8. SAYFA

7. AŞAMA

Üst tabla yan dikmelere kavale yardımıyla birbirine geçirilir.

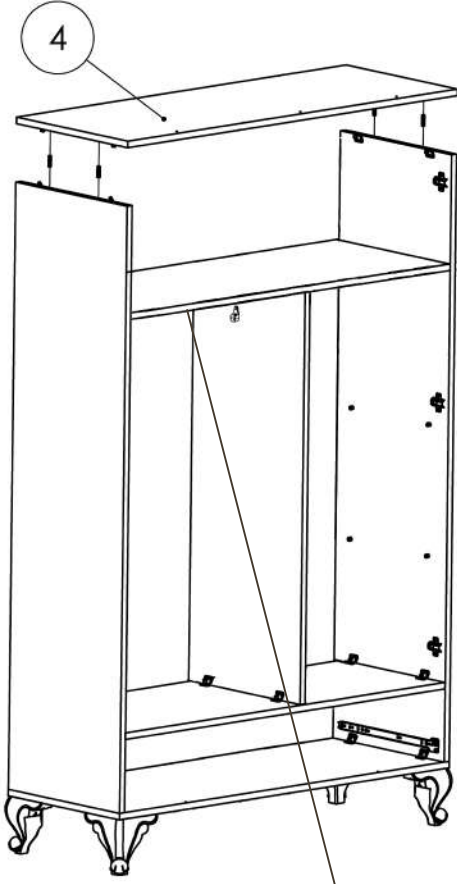

A

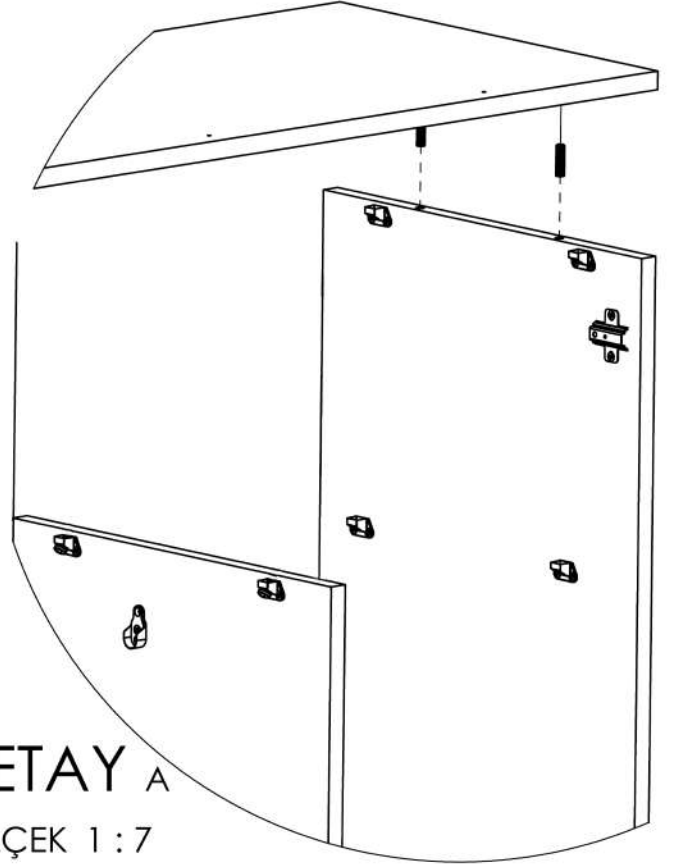

DETAY A

ÖLÇEK 1 : 7

Üst tabla mantar başlı vida ile sağ-sol dikmeye monte edilir.

B

MANTAR BAŞLI VİDA

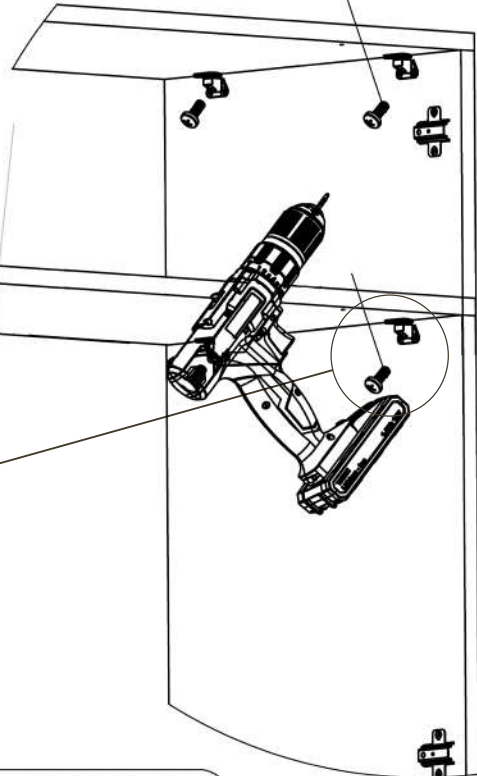

Aynı işlem ortadaki tabla içinde uygulanır

9. SAYFA

8. AŞAMA

170 x 39.7 ölçülerindeki dolap arkalıđı 3.5 x 25 vida ile üst tabla,sađ yan ve orta dikmeye vidalanır.

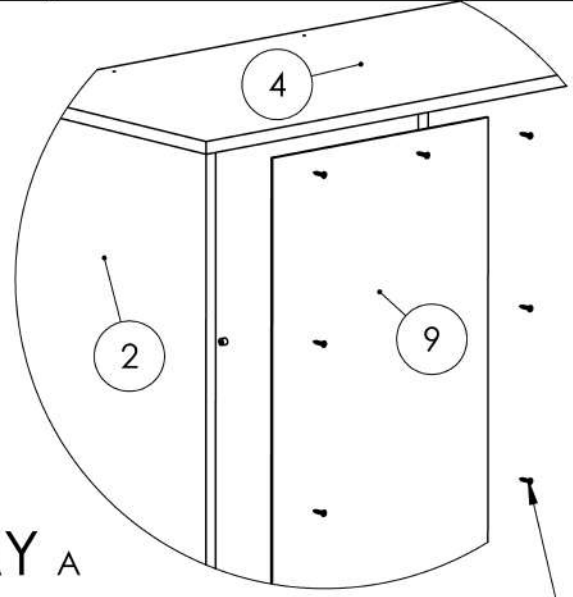

DETAY A

ÖLÇEK 1 : 10

4 X 25 ŞAPKALI VIDA

170 x 39.7 ölçülerindeki ikinci dolap arkalıđını üst tabla ve sol yan'a 3.5 x 25 vida ile vidalanır.Daha sonra H çita ile arkalık birbirine geçirilerek orta dikme ve üst tabla 3.5 x 25 vida ile monte edilerek arkalık montajı yapılır

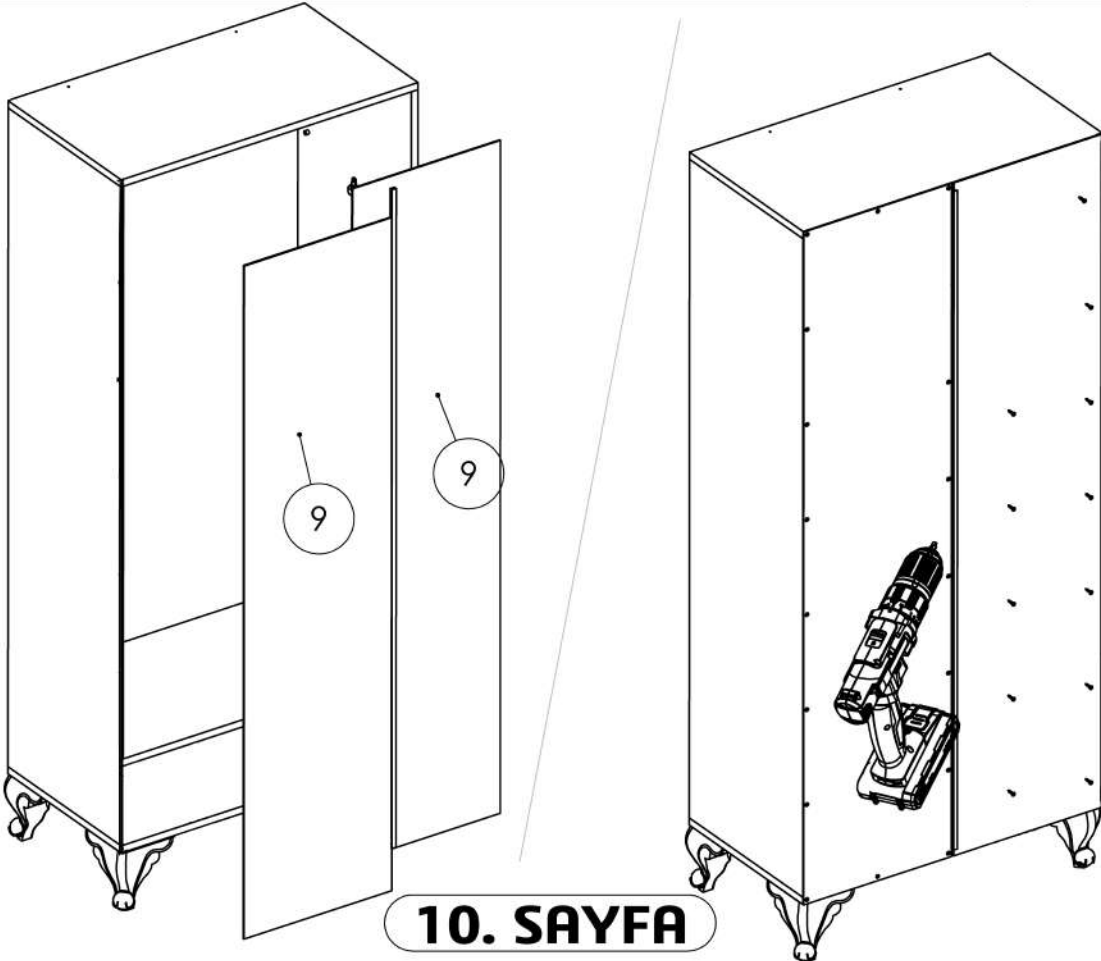

10. SAYFA

9. AŞAMA

11

80 X 13 Ölçüsündeki taç parçasını 4 x 40 vida ile üst tablaya vidalanır. 76.5 X 3.5 Led askı borusu askı flanşına geçirilir.

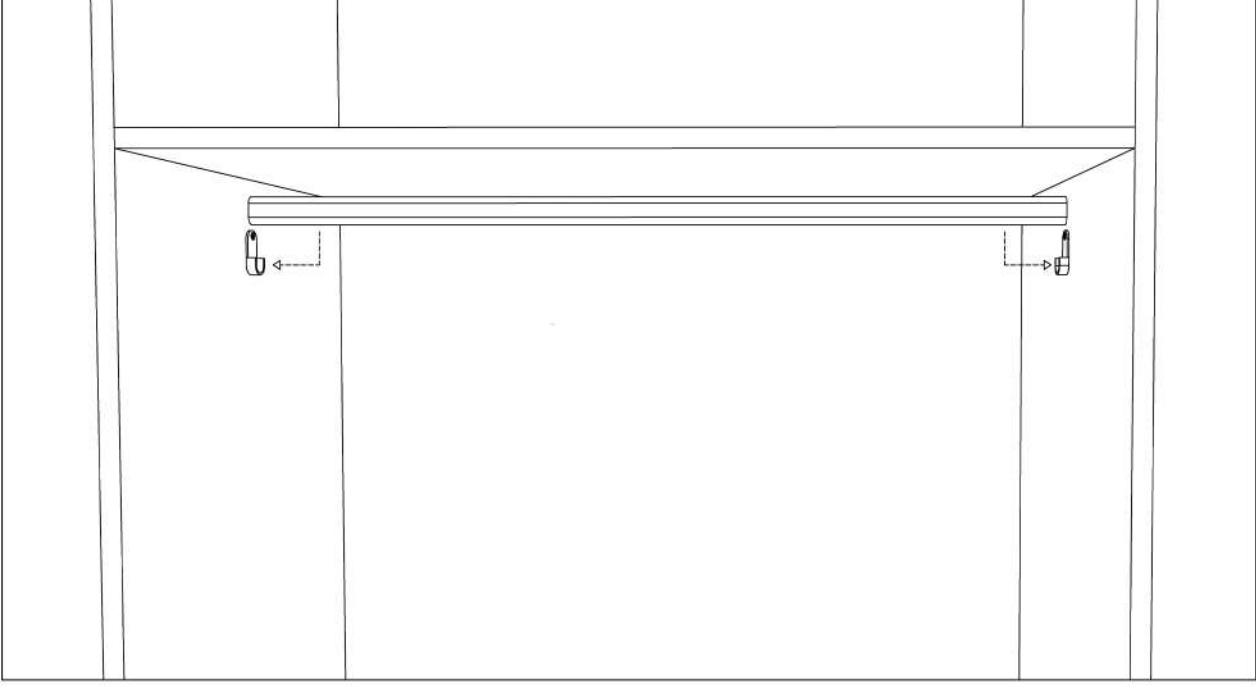

DETAY A

ÖLÇEK 2 : 13

12

11. SAYFA

**44 x 37.3 Ölçüsündeki 3 adet raf'ı
raf pimlerinin üzerine oturtturulur.**

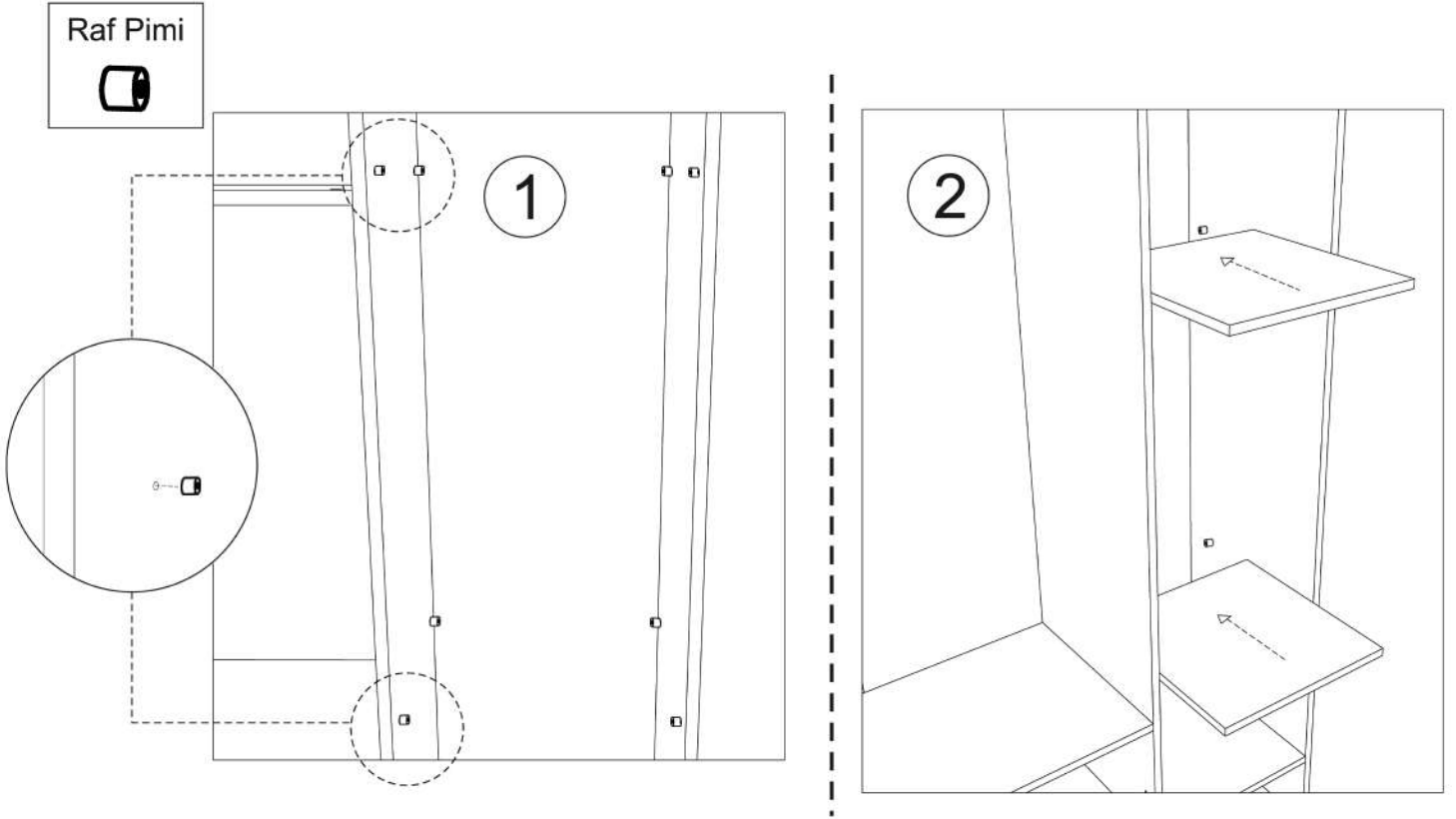

11. AŞAMA

**147.5 x 39.8 ölçülerindeki kapakların menteşe yuvasına
3.5 x 18 vida ile kapaklara vidalanır.kulplar mantar başlı
vida ile kapaklara vidalanır.**

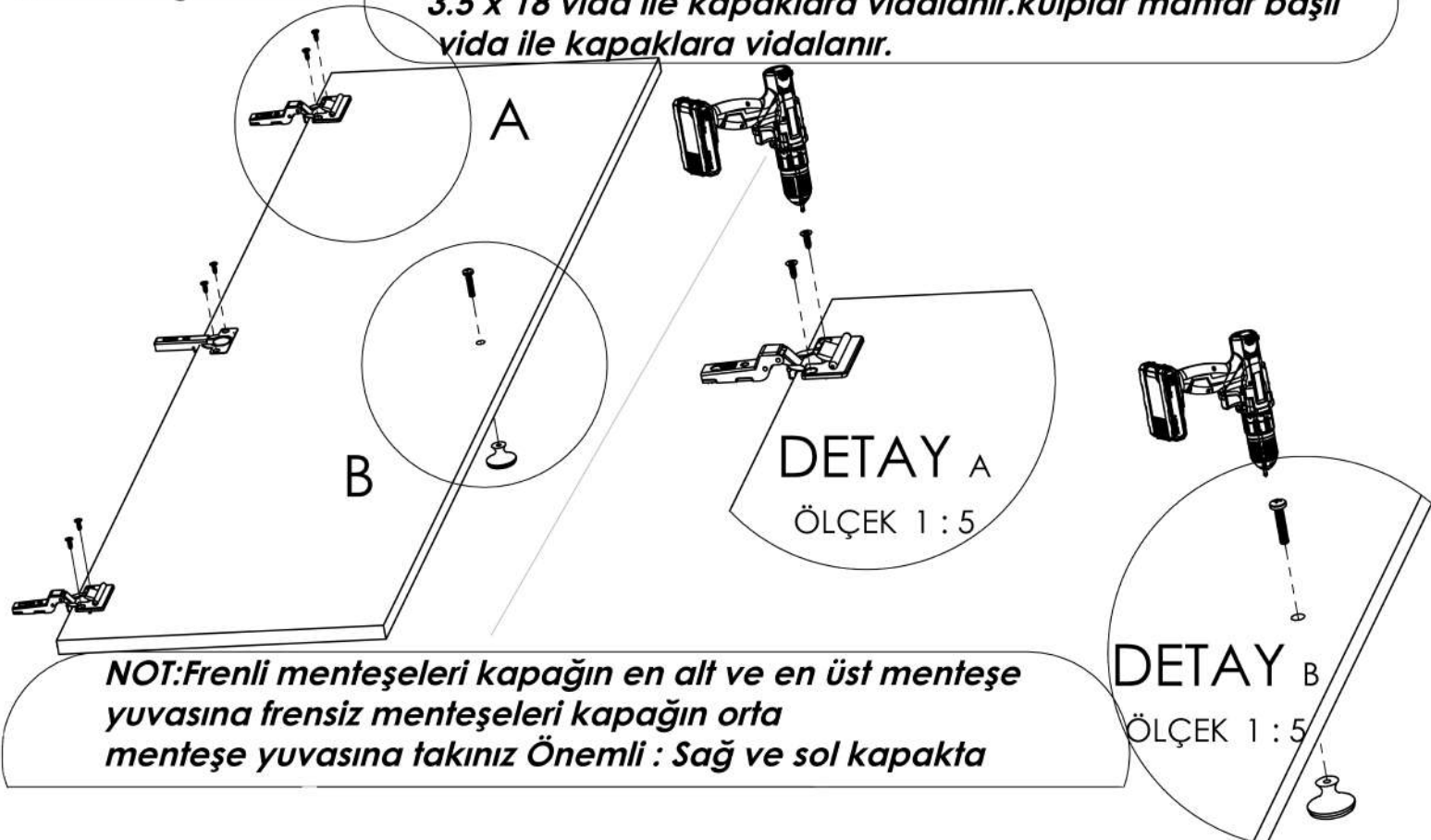

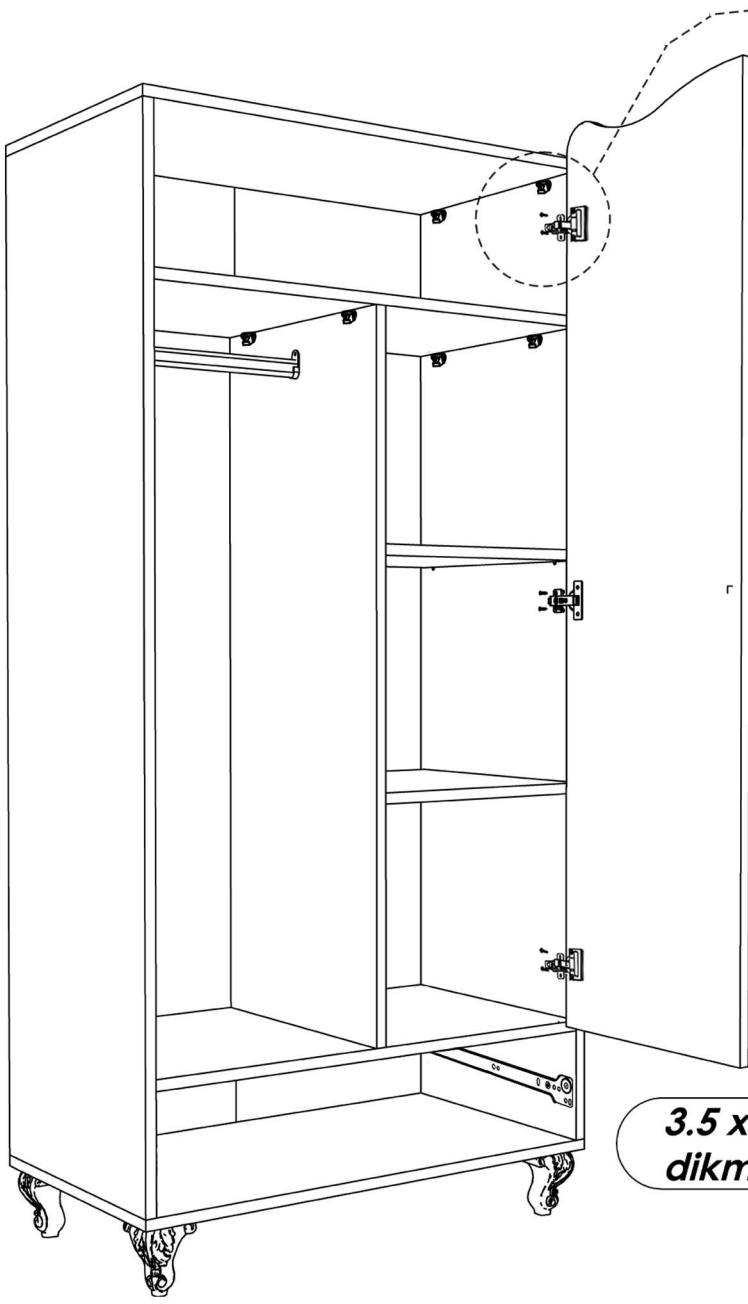

Tüm menteseleri yerlerine takınız

**3.5 x 18 vida ile kapaklar sağ-sol
dikmelerdeki menteşe karşılığına vidalanır.**

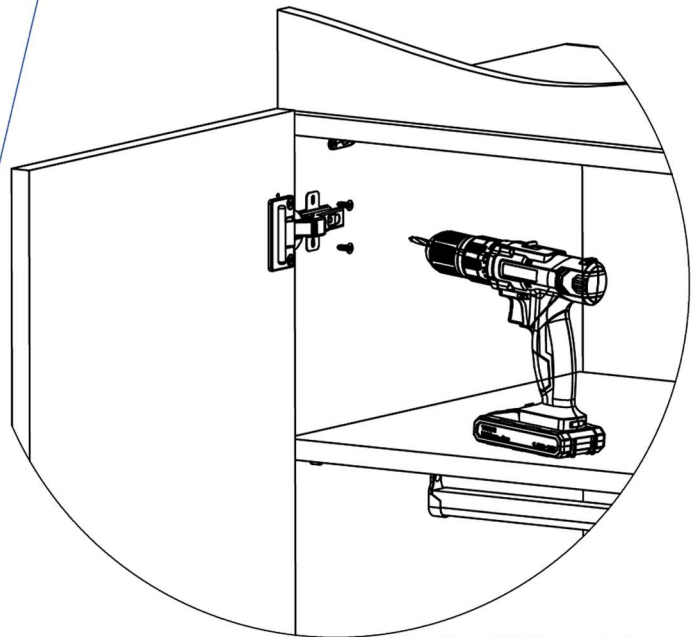

DETAY C

ÖLÇEK 2 : 13

13. AŞAMA

ÇEKMECE KURULUMU

1

çekmece önüne çekmece yanlarını
3.5 x 50 vida ile önceden yerleri
belirlenmiş vida deliklerinden birbirine
vidalanır.

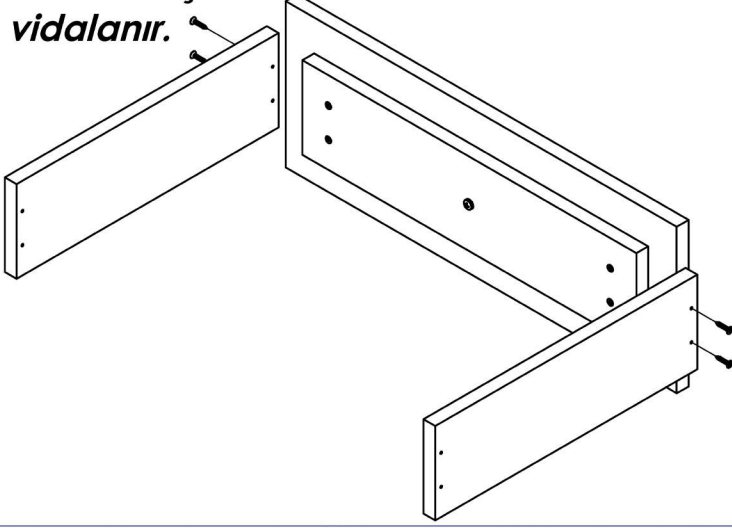

2

çekmece arkasını
3.5 x 50 vida ile çekmece yanlarına
vidalanır.

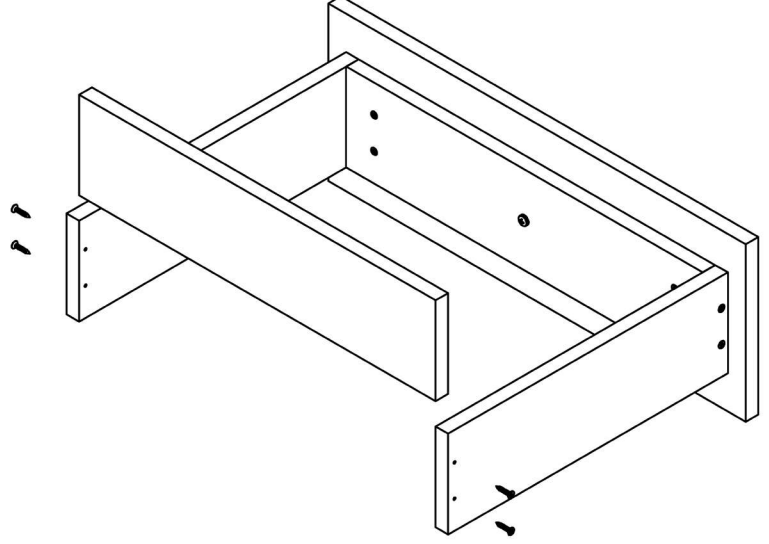

3

çekmece dibini
3.5 x 25 vida ile çekmece yanlarına ve
çekmece arkasına vidalanır.

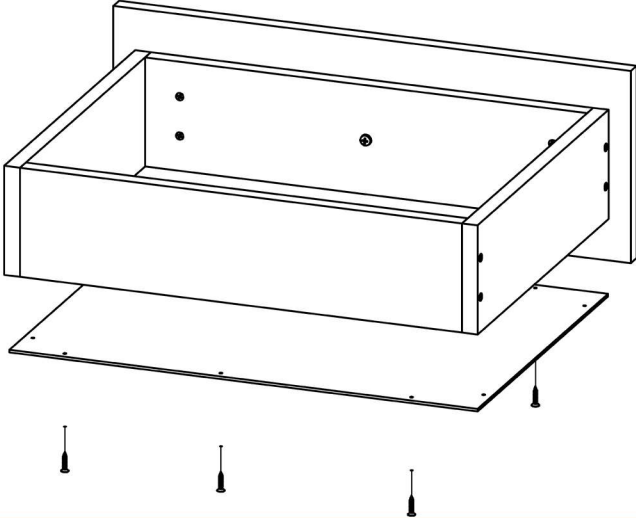

4

Çekmece rayları 3.5 x 18 vida ile çekmece
dibine vidalanır

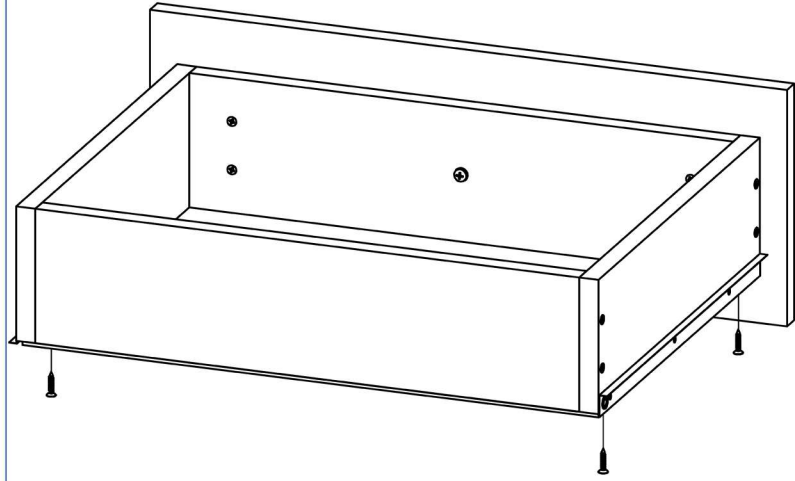

5

Kulp mantar başlı vida ile
çekmece önüne vidalanır.

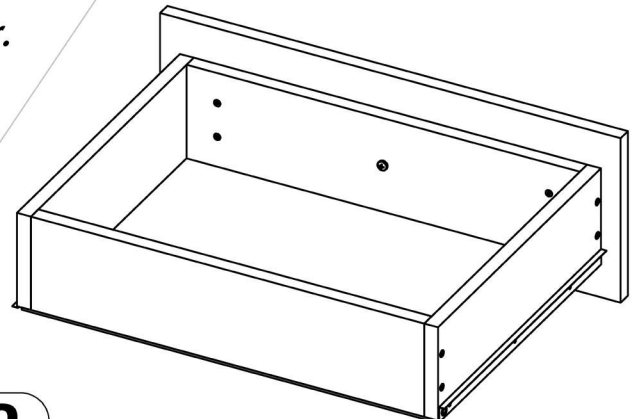
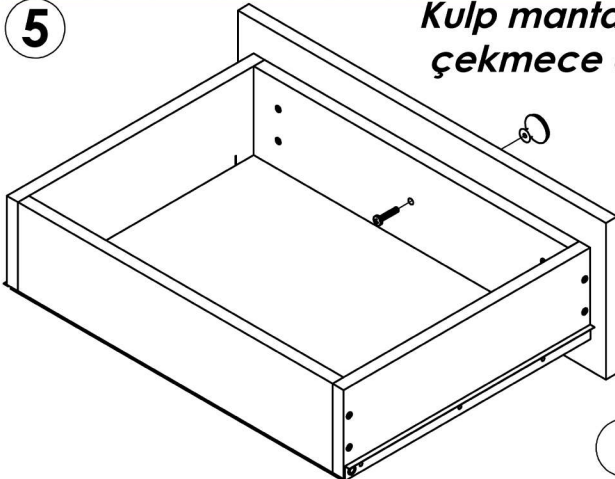

*Montajı yapılan çekmeceleri sağ-sol
dikmedeki sabit raylara geçirilerek
montajı yapılarak dolap montajı bitirilir.*

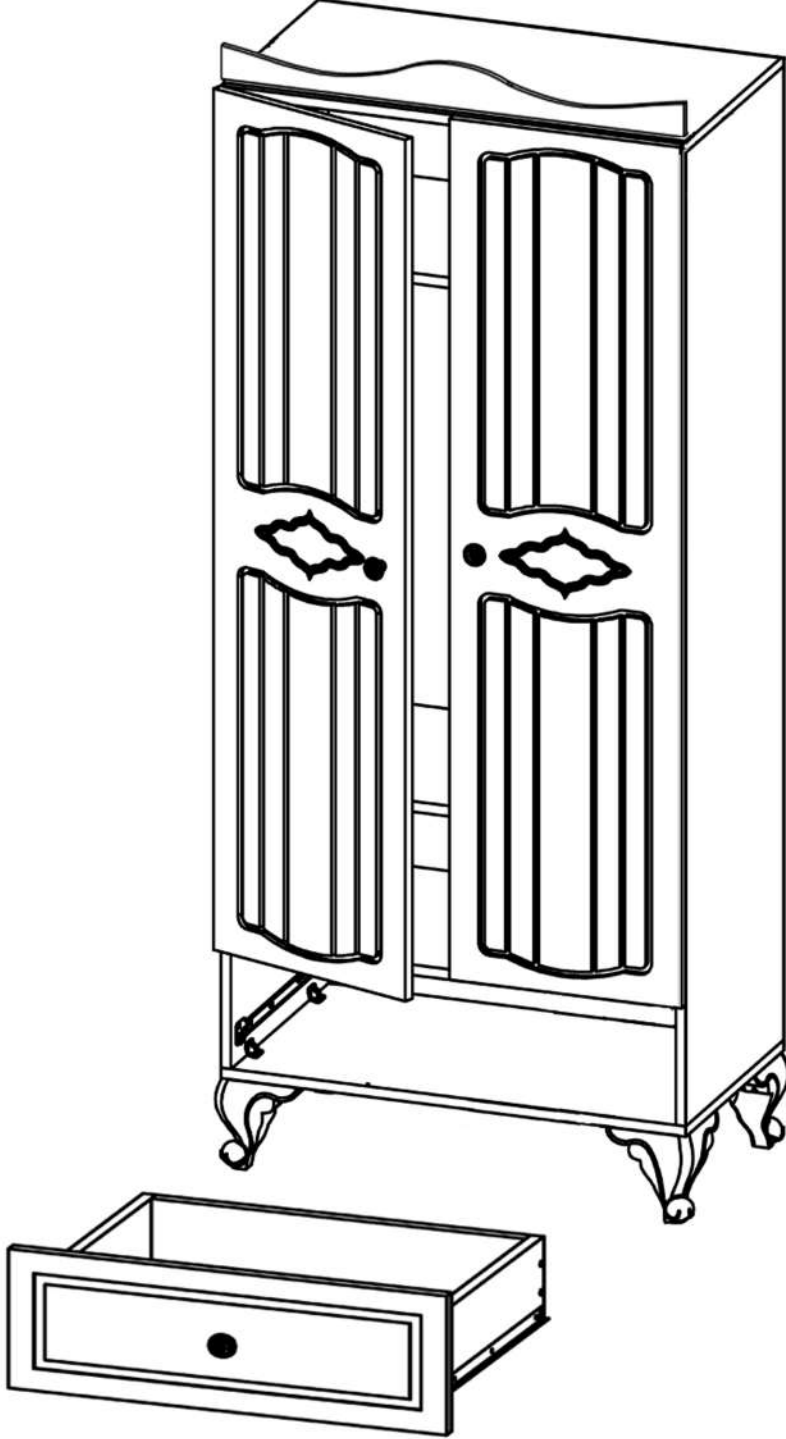

güncü bebe

B A B Y • K I D S • Y O U N G

S I N C E 1 9 8 3